

Compact CPX 621/CPL 621 Specifications

- **Unique Double-Edge profile and corner radii.** Sink lies completely flat on worktop and cloths will not snag on corners
- **One and three quarters bowl configuration**
- **2 x 90mm Wastes with Basket Strainer Wastes.** Capable of adaptation to take Waste Disposal Unit
- **3 colours of bespoke accessories available**
- **Unique drainer design**
- **Retentioned drainer**
- **Classic Compact Franke design**

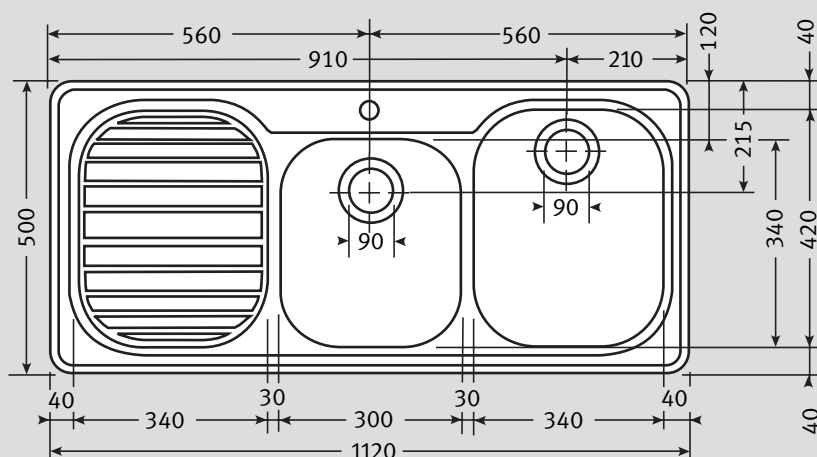

Material:	304 Austenitic 18/10 Stainless Steel	Waste:	1 x Lira 90mm Basket Strainer Waste with overflow 1 x Lira 90mm Basket Strainer Waste	Overflow:	
Application:	Inset or undermount	Bowl size:	340 x 420 x 175 } Bowls welded to frame 300 x 340 x 160 }	Drainer Format:	Left or right hand drainer available
Drainer Format:	Left or right hand drainer available	Cut-out size:	1104 x 484 (cr=20)	Accessories available:	<div style="display: flex; justify-content: space-around;"> <div> <p>Large Strainer Bowl Available in White, Almond, Brown or Black</p> </div> <div> <p>Drainer Tray Available in White, Almond, Brown or Black</p> </div> <div> <p>Drainer Basket/Plate Rack Available in White, Almond, Brown or Black</p> </div> <div> <p>Drainer Basket Stainless Steel</p> </div> </div> <div style="display: flex; justify-content: space-around; margin-top: 10px;"> <div> <p>Food Preparation Platter Mahogany</p> </div> <div> <p>Food Preparation Platter Hygenia</p> </div> </div>
Colour:	Silk Stainless Steel or Linen Finish	Seal:	Factory Fitted Polyurethane Seal	Insulation:	Grey Dynaphon for heat and sound
Heat Resistance:	Up to 300°C	Earthing Point:	Located at end of clip rail	Cabinet size:	

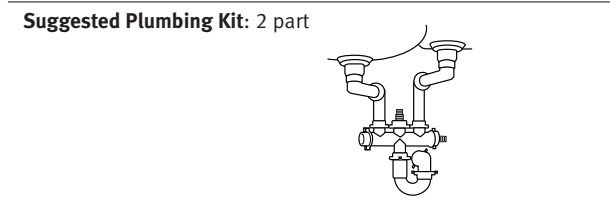
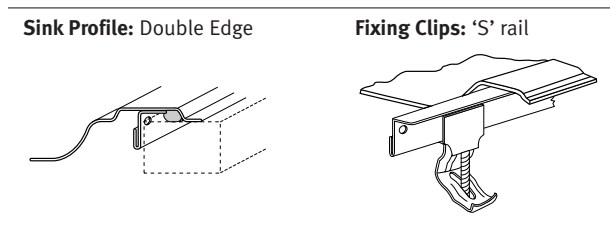

Taps: Any Franke tap can be utilised with this model*.

*Ceramic disc taps in certain installations or where there is a low head of water (below 4 metres) may not provide adequate flow rates. You are advised to check with your supplier.

Some taps may need bracing to avoid flexing of the sink ledge.

Guarantee: Franke sinks are guaranteed for 25 years against manufacturing defect. Franke taps are guaranteed against defective materials and workmanship for 1 year in relation to coatings and finishes, and 5 years in relation to moving parts. Franke will replace (and where appropriate repair) defective sinks. In relation to taps, Franke will where appropriate provide replacement parts for your taps or replace your taps. Any associated or ancillary costs to be incurred by you as a result of replacement of Franke sinks and taps under this guarantee shall in all cases be previously approved by Franke UK Limited. This guarantee is in addition to and does not affect your statutory rights.

The Franke policy is one of continued improvement, and Franke reserve the right to alter models and specifications without notice.